



INSTRUCTION MANUAL

Electrically Driven Specialized Gear Pumps

Model GS 2200 Series

2014

CAUTION!

The ROTOR-TECH electric drive specialized gear pump (Model GA, GC or GS) is a precision device that depends upon a very tight fit between the pumping gears and the housing in which they rotate. Clearances of less than $\frac{1}{2}$ thousandth of an inch are common (.012mm).

When **hot** glycol is suddenly drawn from the storage tank into the pump (particularly on a new start-up), the gears **expand** more rapidly than the housing. On start-up, the pump is at **ambient** temperature. As glycol is suddenly drawn from the surge tank, it enters the pump **hot**, resulting in a sudden rise in temperature. This can cause a momentary **lockup** of the pump, which will result in **internal pump damage**.

When starting an electric pump, you **MUST** "jog" the motor by turning the power on and off for short periods of time, pausing between "jogs" to allow the heat to react in the pump. This **MUST** be done until the pump housing has reached the temperature of the fluid being pumped. The pump can then be turned on as normal, and flow rates adjusted as required.

If it is impossible or inconvenient to "jog" the electric motor to minimize thermal shock, then start the motor at about 10 Hz. Then after some increase in temperature is felt in the pump slowly increase the speed by increasing the hz of the power to the motor. This should not take more than about two minutes. This must be done with the by-pass open to the dry storage tank or the reboiler or the still column. After the pump is running at the desired speed and it is completely warmed up, then slowly close the by-pass valve.

Under no circumstances should the pump be started under load, (' dead-heading '). Remember, it's a positive displacement pump and they should never be started against a block valve or high pressure.

In our pumps, the bushings rely on a thin film of fluid (TEG) between the shaft and the bushings. This film will not develop properly if the pump is started under load. We recommend that the pump be started with a by-pass valve or bleed valve open, which normally is piped back to reboiler or heat exchanger, and allow the pump to run for a minimum of 3-5 minutes before load is applied to ensure that the lubricating film between the bushings and the shaft is developed. If this is not practiced, the lubricating film will not be established which will allow the pump to run dry and shorten the longevity of the pump.

2014

In addition, we recommend that low pressure suction filters (25-50 micron) be installed immediately before the pump along with a vacuum gauge, set a benchmark (PM's) for the gauge reading and monitor daily/weekly to ensure the filter element is not obstructing flow to the pump suction.

In extremely cold climates, it is often advisable to insulate the outside of the pump to keep it near the temperature of the glycol and the gears. Rotor-Tech can supply very effective insulators if needed.

The GS models are not nearly as susceptible to damage from thermal shock as are the GA & GC models. Usually one "jog" is sufficient. Perhaps two "jogs" in extremely cold conditions with glycol temperatures above 175°F at the pump.

As mentioned above, our GS model pumps have pressure wear plates which allow the clearances between the gears and the plates to be maintained at the proper clearance and they do this by means of a gasket/backup on the back of the plates. This allows for expansion to the gears when the fluid and pump casing start heating up, which allows for the proper clearances, therefore, under most circumstances, the jogging sequence can be greatly reduced or eliminated in our GS model pumps.

Regarding temperature, should the temperature rise above the 200 ° F (which is our maximum temperature allowed for pressures over 125 psig) lets say for brief periods of time, the viscosity of the TEG will be reduced and thus will reduce the lubrication of the internals. Short durations above 200 ° can be tolerated but should the temperature rise above 200 ° F and stay there then premature wear to the internals would occur. The viscosity of TEG @ 200 ° F is slightly above 4 cP, the lower the viscosity the more rapid the progression of internal wear. Indication of this gradual wear occurring will be in a significant increase in pump noise and vibration.

Rotor-Tech manufactures a Thermocouple Control System that provides totally automatic and proper "jogging" of the electric motor to eliminate thermal shock. All the operator does is turn on the motor and forget it.

Other precautions to take and recommendations:

1. Check the pump casing temperature (with a hand held temperature gun) on a weekly basis and report any significant rise in the pump casing temperature as this would indicate a rise in internal friction and/or a potential problem with the low pressure heat exchanger.
2. Check the oil level in the oil reservoir between the pump and the electric motor monthly to ensure proper lubrication of the seals and coupling.
3. Some customers prefer to switch from the primary to the backup pump on a monthly basis, we do not recommend this as with any rotating equipment the starts and stops are harder on the internals than continuously running the pump. If secondary pump needs to be checked, simply turn secondary pump on with primary pump running and bypass valve slightly open to maintain flow control, and then shut secondary back off once proved to be in operational order.
4. Avoid washing down the pump with direct water spray while the pump is in service. Washdown could cool the pump casing rapidly and cause thermal expansion issues between the gear housing and the gears which could result in premature internal wear. If the location is prone to heavy rain or water spray the pump should be covered with a shield.
5. Monitor noise levels emitted from the pump on a daily basis. A rise in noise would indicate internal wear, cavitations or large particulate reaching the pump which will be detrimental to overall pump life.
6. Maintain the fluid PH level so that it is slightly basic (7- 7.5)
7. Keep at least one spare pump head on hand at all times.
8. Operation must have a properly specified and dedicated suction filter installed and functioning prior to commissioning.
Please contact your Rotor-Tech representative for special assistance.

“ROTOR-TECH SPECIALIZED GEAR PUMPS”

Important Information Concerning the Rotor-Tech Electrically Driven Glycol Pumps GS Series

Please read all of this before installing or start up.

I. Check Valve **MOST IMPORTANT**

The single most important and most necessary item that must be provided by the user when installing a “ROTOR-TECH SPECIALIZED GEAR PUMP,” is a good check valve in the high-pressure discharge line.

If the pump is turned off for any reason it is absolutely necessary that a check valve prevent high-pressure fluid from flowing back through the pump. If high-pressure fluid is allowed to back up into the pump and if simultaneously a suction line valve were closed, then the high pressure could cause the pump shaft seal to leak. This could allow fluid to flow into the oil reservoir. This leakage of oil and fluid (TEG, EG or MDEA) would be undesirable, requiring cleanup and could be dangerous to personnel in the vicinity.

Another possibility can occur if high-pressure fluid would act upon the pump with the suction line valve open. In this case the pump becomes a hydraulic motor and could damage the electric motor.

Most glycol dehydrators and similar production or process equipment are already equipped with good check valves to enhance the safety of their systems. Be certain to test any check valve for proper operation before installing the “ROTOR-TECH SPECIALIZED GEAR PUMP.”

II. Bleed Valve and By-Pass Valve

The “ROTOR-TECH SPECIALIZED GEAR PUMP” must be primed before it will pump at high pressure. The pump is self-priming if the air in the pump is bled off so that liquid can be drawn into the pump from the suction supply. It is recommended that an air bleed-off valve be installed in a “Tee” between the pump discharge port and the check valve. Many installations have the Rotor-Tech “Flo-Gage” installed in the suction line to the pump. With this arrangement it is very easy to bleed off air into the “Flo-Gage” through its bottom NPT connection. No fluid will be lost to the environment if the “Flo-Gage” is used. As soon as the pump is primed, close the “Flo-Gage” through its bottom NPT connection.

2014

This valve can also be used to relieve pressure from the pump during start-up. Often a second larger valve and "Tee" is installed for this purpose. The purpose being to never start a positive displacement pump under any load.

Do not allow the pump to run dry. The gears and shafts in the pump rely upon the fluid being pumped to lubricate and cool them. The pump can be damaged if allowed to run dry for more than a few seconds.

III. Rotation

The electric motor must be wired to provide rotation in the counter-clockwise direction when facing the PUMP end. (Clockwise rotation when facing the fan end of the electric motor.) Note the "ROTATION" arrow that is fastened to the top of the oil reservoir. This indicates the direction of rotation. Continued rotation in the wrong direction could damage the pump.

IV. Flow

Flow through the pump is from right to left as indicated by the "FLOW" arrow on the face of the pump End Cover. This arrow is marked "IN" for the suction side of the pump and "OUT" for the high-pressure discharge side. If it is absolutely necessary that flow be from left to right due to existing piping conditions the pump can be indexed 180° to accomplish this change. Or, if necessary, the pump can be indexed 90° to achieve flow in a vertical direction from top to bottom. Never install a gear pump to pump upward from bottom to top. Do not attempt to index the pump until you have a complete understanding of Section V below.

V. Installing and Piping

The motor feet can be bolted into the desired position at the jobsite. Shims or equivalent alignment members should be installed under the base to facilitate alignment with existing or new piping. Fine vertical adjustments for alignment can be made by shimming with washers between the motor feet and the mounting base.

IMPORTANT

The "ROTOR-TECH SPECIALIZED GEAR PUMP" is a precision device that depends upon a very close fit between the pumping gears and the housing in which they rotate. Clearances of less than 1/2 thousandth of an inch are common. If piping alignment is not good, it is possible to put stresses and strains on the gear housing enough to cause bending, and thus rubbing of the gears on the inside of the housing. If this occurs, severe damage could result and, at best, the life of the unit will be reduced.

Therefore, great care should be taken to insure the piping is not in misalignment with the inlet and outlet of the pump.

It is recommended that flat-faced unions or the proper hydraulic fittings be used in connecting the pump. These unions or fittings make it very easy to remove the pump for replacement or servicing. If flat faced unions are used, the pump can be removed by simply unscrewing the two union nuts and removing the four 5/16-18 UNC Hex-head screws (1/2" hex or open end wrench size). The pump is then simply pulled off the oil reservoir with no interference from the unions. Standard unions often require heavy prying of the piping to remove the pump. This is difficult and time-consuming. An alternate way to insure piping alignment and ease of replacement is to connect the pump using enough flexible tubing or high-pressure hydraulic hose to prevent stresses and strains on the internals and to cut down on man-power when changing out a pump.

VI. Pressure Relief Valve

The oil reservoir has a short standpipe extending upward. This pipes internals consist of a two "O" Ring and ball pressure relief valve. The purpose of this relief valve is to prevent pressure from building up in the oil reservoir. If the reservoir is overfilled, excess oil will run out of the pressure relief valve until equilibrium is reached. Also, as the air and oil in the reservoir heat up, the relief valve will prevent pressure build up. If the pump seal fails or leaks and there is simultaneously positive suction pressure, the seal leakage will be evidenced by oil or the pumped fluid exhausting from the pressure relief valve.

VII. Oil Reservoir for Seals

An additional oil reservoir is provided to lubricate the two Oil Seals in the "C" Face Adapter or often call the Motor Adapter. There is a 1/4 NPT hollow hex pipe plug to fill and drain this small reservoir. Check the oil level occasionally by removing the Fill Plug on top of the "C" Face Adapter. Add oil if necessary and replace the plug. Excess oil will simply be pushed under the Oil Seals without damage.

VIII. Weep Hole for Oil Seals

If oil begins to leak out of the weep hole, it means that the Oil seals are worn too much to prevent leaking. A little leakage is not important, but when noticed, one should plan to replace the oil seals as soon as possible.

MODEL GS SERIES

All of the precautions and procedures referred to in "Instruction Manual for Electrically Driven Specialized Gear Pumps" apply to the GS series pumps.

DISASSEMBLY PROCEDURE

Refer to Exploded View/Parts List:

1. Score a line or center punch marks on each of the three main parts (Stator 5, Gear Housing 9 and End Cover 11). Do not center punch close enough or hard enough to the mating surfaces to cause bulging of the flat surfaces. These marks will be helpful for alignment during assembly.
2. Grip the pump in a vise with shaft pointing downward. Here again do not tighten the vise on or near the mating flat surfaces or damage could occur.
3. Remove the four Cap Screws 13 and washers 12 (washers are optional).
4. Remove the End Cover 11. The Pressure Wear Plate 7, may remain in the Gear Housing 9. Be very careful in removing the Pressure Wear Plate. Do not mar or scratch any of the flat surfaces.
5. Lift up and remove the Gear Set 10. Keep the two gears together as removed. They have been run together and will be most efficient if kept mated the same on re-assembly.
6. Remove the Gear Housing 9 by lifting it straight up. Remove and keep the four dowel pins. Inspect the two Housing Gaskets 8. If damaged, they should be replaced.
7. Remove Pressure Wear Plate(s) 7 from Gear Housing 9. Be very careful not to damage any of the components. If the pressure Wear Plates 7 are stuck be very careful to remove with light prying. Light tapping with a wooden handle may be necessary. Never use a metal hammer or strike any part of a gear pump. This will certainly damage some components and can cause chipping and possible injury to the eyes of the worker. Remember that the gears, shafts etc. are very hard and brittle and can chip easily if struck with a hard metal hammer. After the Pressure Wear Plates 7 are free, remove the channel seals from the backside and discard.
8. Place Stator 5 in vise with Snap Ring 1 facing up. Remove Snap Ring 1, Ball Bearing 2 and Seal Back-up 3. Eye protection should always be worn when working with snap rings. Inspect the Shaft Seal 4 for damage and excessive wear. If replacement is necessary remove Seal with screwdriver.
9. Inspect the two DU Bushings in Stator 5 and two in End Cover 11 for excessive wear. If replacement is necessary, use the Bushing Puller Assembly tool to remove the four bushings.

ASSEMBLY PROCEDURE

1. Inspect all flat surfaces and lap them on a piece of 400-grit sandpaper on a very clean surface plate. If shiny high spots are found continue lapping until you are positive that no high spots remain. Thoroughly wash all parts that are to be reused.
2. To install new DU Bushings 6 in Stator 5 and/or End Cover 11 use an arbor press or hydraulic press to press in Bushings 6. Do not use a hammer. Install the top Bushings in Stator 5 and End Cover 11 with the broach groove in the 12:00 O'clock position. Install the bottom Bushings with broach groove in the 6 O'clock position. Be sure all Bushings are perfectly even with the top surface of the Stator 5 and End Cover 11. It may be necessary to lap the Stator and End Cover again after installing the Bushings to ensure they are even with surfaces.
3. Place Stator 5 in a vise with Bushings side up. Insert two dowel pins 14. Inspect Gear Housing 9 for wear. If wear is excessive, replace with new housing. Fill one gasket groove on Gear Housing 9 with grease. Insert Housing Gasket 8 in groove. The grease will keep the Gasket from falling out during assembly. Position Gear Housing 9 over Stator 5 with Gasket down and the large suction port on the right side. Tap the Housing down with a rubber mallet.
4. Inspect the Pressure Wear Plates 7. If they are worn replace with new ones. Install a new channel seal on back of Pressure Wear Plate 7. Do not get grease or oil on the channel seal side. Place the Pressure Wear Plate 7 in Gear housing 9 with high-pressure groove to the left side (see drawing on exploded parts drawing). Slide the Pressure Wear Plate to the bottom of Gear housing with the channel seal side down toward the Stator and the flat surface toward you.
5. Inspect the shaft and gear surfaces for wear. If wear is excessive, replace with new parts.
6. Install Gear Set 10 through Gear Housing 9 & Stator 5.
7. Insert two Dowel Pins 14 in Gear Housing 9.
8. Insert Housing Gasket 8 in groove in Gear Housing 9. Apply a light film of grease to the gasket. Install channel seal in the back of the Pressure Wear Plate 7, then install into the Gear Housing 9 with high-pressure groove to the left side. The channel seal of the Pressure Wear Plate should be facing you. Do not get grease or oil on the channel seal.
9. Place End Cover 11 on Gear Housing 9. Install four Cap Screws 13 and using a torque wrench tighten cap screws to 100 foot pounds. Test the pump's ability to rotate by turning Spline shaft with Vice Grips.
10. To install a new Shaft Seal 4, carefully clean and degrease the seal seating area in Stator 5. Apply grease to the outside of the "O" Ring on the new Shaft Seal 4. Place a seal installation tool over the spline of the drive shaft. Press the seal in with lip pointing toward the gears just past the seal installation tool using your fingers or a metal bar of proper diameter. Remove seal installation tool and use a metal bar of proper diameter and an arbor press to complete the installation of the Seal. Do Not hammer on the seal or use a punch type tool or the seal will be distorted and will leak.
11. Install Seal Backup 3 with lip toward seal.
12. Install Thrust Bearing 2.
13. Install Snap Ring 1. Wear eye protection.

MODEL GS 2200 SERIES GLYCOL PUMPS ONLY

PARTS LIST

REF. GS EXPLODED PARTS LIST ITEM NUMBERS

ITEM NO. ON EXPLODED VIEW	DESCRIPTION	MODEL SERIES	PART NUMBER	QTY. PER UNIT
1	Snap Ring	All GS 2200	2240023	1
2	Thrust Ball Bearing	All GS 2200	2030131	1
3	Seal Backup	All GS 2200	2591062	1
4	Shaft Seal	All GS 2200	2122270	1
5	Stator W/DU Bushings	All GS 2200	2160050	1
6	DU Bushings	All GS 2200	2030052	4
7	Pressure Wear Plates	All GS 2200	2450220	2
8	Gaskets	All GS 2200	2260301	2
9	Gear Housing	GS 2204	2052204	1
9	Gear Housing	GS 2206	2052206	1
9	Gear Housing	GS 2208	2052208	1
9	Gear Housing	GS 2210	2052210	1
9	Gear Housing	GS 2212	2052212	1
9	Gear Housing	GS 2214	2052214	1
9	Gear Housing	GS 2216	2052216	1
9	Gear Housing	GS 2218	2052218	1
9	Gear Housing	GS 2220	2052220	1
10	Gear Set 7/8 – 13T Spline	GS 2204	2202204	1
10	Gear Set 7/8 – 13T Spline	GS 2206	2202206	1
10	Gear Set 7/8 – 13T Spline	GS 2208	2202208	1
10	Gear Set 7/8 – 13T Spline	GS 2210	2202210	1
10	Gear Set 7/8 – 13T Spline	GS 2212	2202212	1
10	Gear Set 7/8 – 13T Spline	GS 2214	2202214	1
10	Gear Set 7/8 – 13T Spline	GS 2216	2202216	1
10	Gear Set 7/8 – 13T Spline	GS 2218	2202218	1
10	Gear Set 7/8 – 13T Spline	GS 2220	2202220	1
11	End Cover w/DU Bushings	All GS 2200	2100278	1
12	Washers – OPTIONAL	All GS 2200	2133002	4
13	Cap Screws X 4.5"	GS 2204	2130140	4
13	Cap Screws X 4.5"	GS 2206	2130140	4
13	Cap Screws X 4.5"	GS 2208	2130140	4
13	Cap Screws X 4.5"	GS 2210	2130140	4
13	Cap Screws X 5"	GS 2212	2130141	4
13	Cap Screws X 5"	GS 2214	2130141	4
13	Cap Screws X 5.5	GS 2216	2130142	4
13	Cap Screws X 6"	GS 2218	2130145	4
13	Cap Screws X 6.5"	GS 2220	2130146	4

2014

S A E 4 BOLT FLANGE

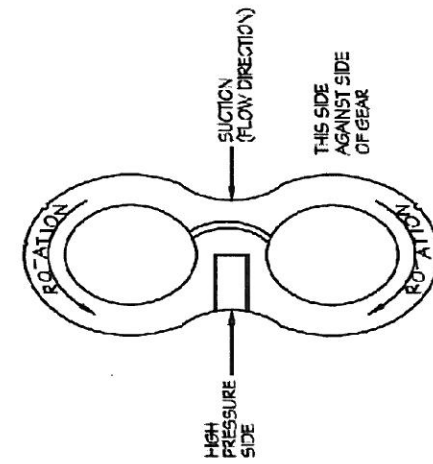
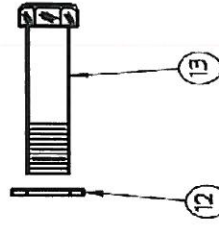
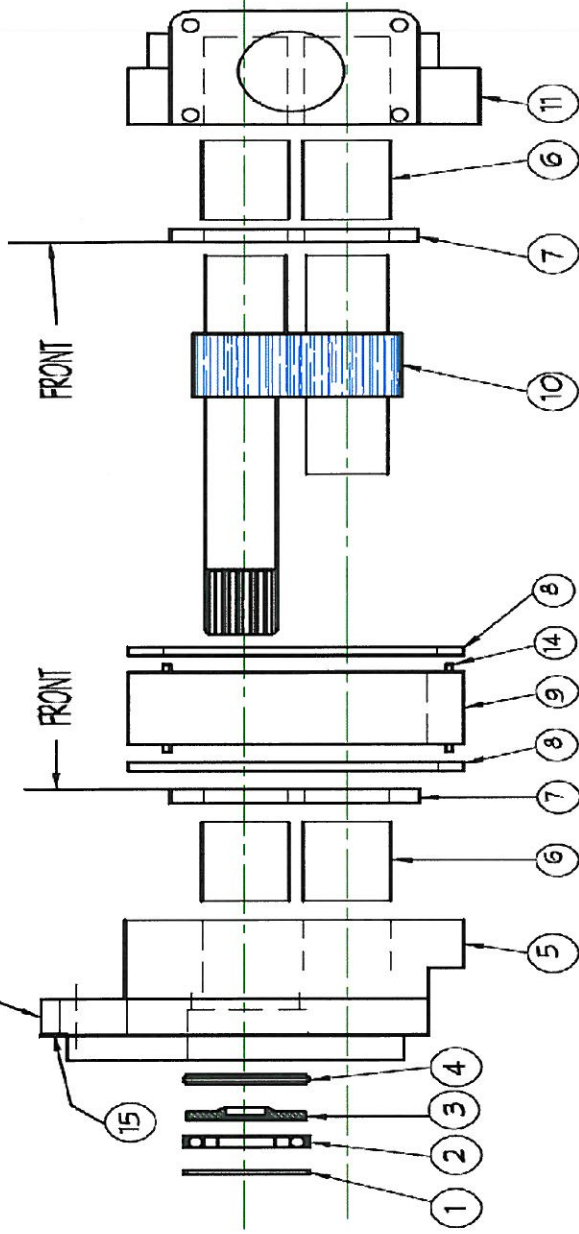

FRONT OF PRESSURE WEAR PLATE

ITEM NO.	DESCRIPTION
1	SNAP RING
2	THRUST BALL BEARING
3	SEAL BACK-UP
4	SHAFT SEAL
5	STATOR W/DU BUSHINGS
6	DU BUSHINGS
7	PRESSURE WEAR PLATES
8	HOUSING GASKET
9	GEAR HOUSING
10	GEAR SET
11	END COVER W/ DU BUSHINGS
12	WASHERS
13	CAP SCREWS
14	DOWEL PINS
15	MOUNTING GASKET

ROTOR - TECH INC
HOUSTON TEXAS

REVISED: 4.02.08

TITLE: **EXPLODED PARTS LIST**

MODEL:
DRAWN: PM
CHECKED: JC
APPROVED:

SCALE: NTS
DRAWING #

* These items are not used on TEFC
Brook Crompton Motors. Seal is in motor.

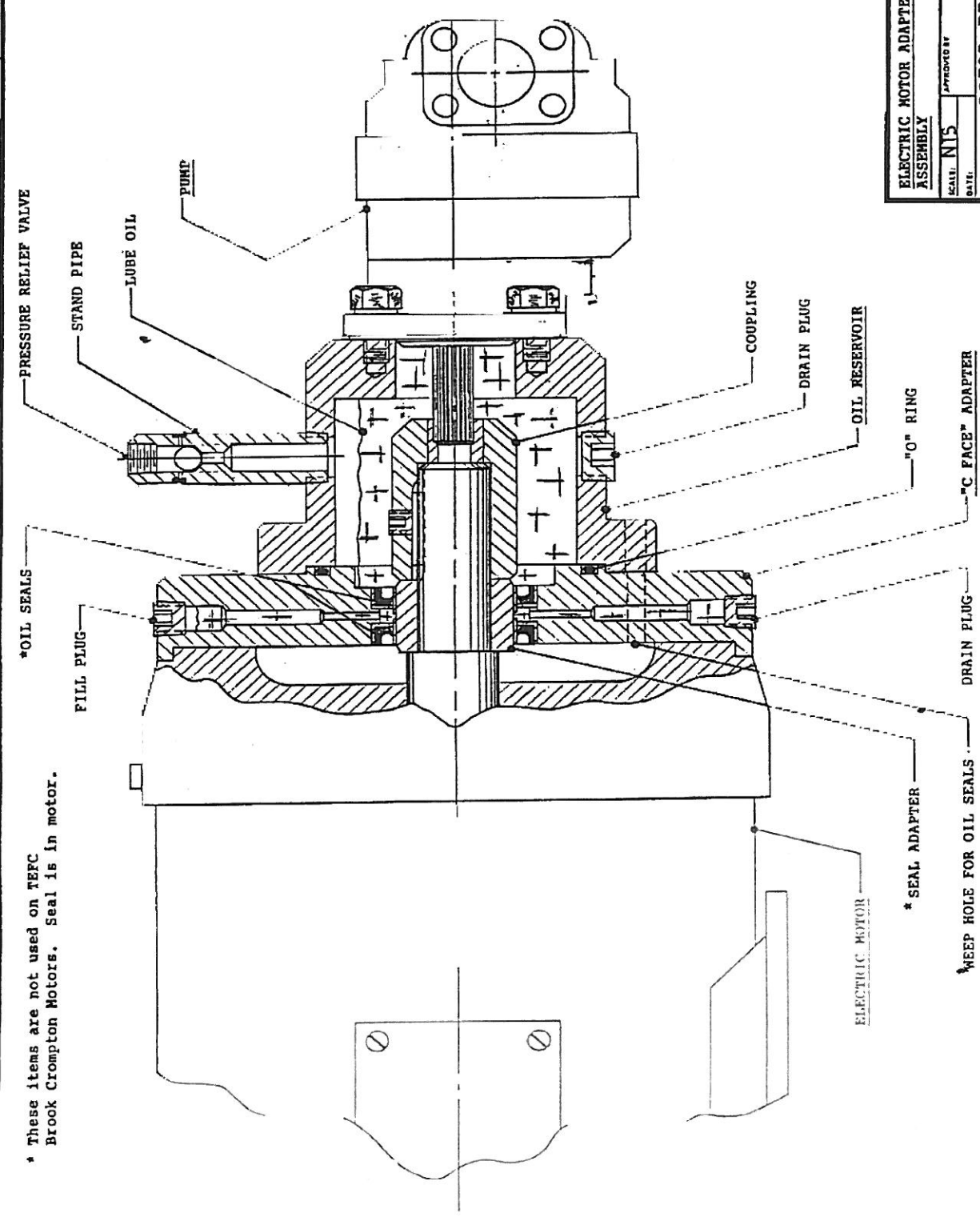

ELECTRIC MOTOR ADAPTER ASSEMBLY		DESIGNED BY	TWA
SCALE: NTS	DATE:	APPROVED BY	
ROTOR-TECH INC HOUSTON TEXAS		DESIGNED NUMBER	N/A
GS 2200			

LUBRICATION

All Rotor-Tech electrically driven glycol pumps have an oil reservoir and a "C or D Face" adapter. Refer to the cross sectional drawing on the opposite page to locate these two components. To change oil in the oil reservoir remove the Drain Plug (1/2" NPT Socket type) at the bottom of the oil reservoir. Check old oil for signs of glycol contamination. A thick, ropy, grayish, opaque appearance indicates glycol contamination of the oil. If this occurs it may indicate that the pump lip seal is leaking. Occasionally a new pump seal will leak for a short while and then stop all together. If the pump is fairly new, simply clean the oil reservoir and pour in new oil. Remove the "Stand Pipe" or top plug (1/2" NPT Socket type) to pour in new oil. Run the pump a few days and check again. If contaminated again, the pump lip seal should be replaced. Pour in oil to just cover the coupling. This is adequate to lubricate open ball bearing and the lip seal in the pump. Also, the front oil seal in the "C Face" adapter will be lubricated.

If the oil reservoir is overfilled the excess will be forced out of the "O" ring covers near the top of the standpipe. Simply wipe away the excess oil until equilibrium is reached. Increased temperature in summer will cause expansion of the oil and a small additional amount may come out. Again, just wipe it away. When the proper level is reached no more oil will be forced out. High-speed motors (3600 RPM) will force out more oil than slow speed (1800 or 1200 RPM) at 50 HZ this is of course 3000 RPM and 1500RPM.

In the "C or D Face" Adapter there are two oil seals. These are lubricated by a very small additional oil reservoir between them. NOTE: "Fill Plug" and "Drain Plug" that are small (1/4" NPT Socket type) at top and bottom of the "C or D Face" adapter. Remove the Fill Plug, fill the cavity completely full. Screw the Fill Plug back tightly. Any excess oil will be forced out into the larger reservoir. If the motor is mounted on floor plate it is impossible to remove the lower drain plug. If it can be easily removed it is good to drain the small reservoir and replace the oil. This is not very important, simply checking and filling at the top is all that is necessary for many years of operation.

Oil Seals in the "C or D Face" Adapter will eventually wear out. Indication of this will be from oil from the large Oil Reservoir will run out of the "weep hole for oil seals" and will be evidenced by slow seepage at the front flange of the Oil Reservoir. When this occurs, usually after years of operation, the oil seals must be replaced.

All oil reservoirs are pre-filled by Rotor-Tech before shipping the pump/motor assemblies, unless shipping overseas. Any good regular automotive motor oil 10W-30, 30W, 5W-50 or any ATF (Automatic Transmission Fluid) can be used. In very cold climates use the same very light oils used in automobiles for these climates. Special "Chain Oils" that pour (very slowly) at - 70°F are available in Canada, Norway, etc.

Electric motor ball bearings should be lubricated per the electric motor manufacturer's lubrication specifications, located in the motor manual. If lubrication specifications cannot be found, follow below recommendations. (NOTE: Some motors may have permanently greased bearings, of which does not require re-greasing of the bearings.)

Electric motor ball bearings should be re-greased annually with the grease recommended by the electric motor manufacturer. The recommended grease is Chevron SRI, Shell Dolium R or any of the many equivalents.

To grease the motor ball bearings, first remove the lower plugs (usually 1/8" NPT). Install a grease fitting on top, either 1/8NPT or 10-24-thread type. Using a grease gun pump in several strokes until old grease is forced out of the lower plugholes. Run the motor for about 30 minutes with the lower plug holes still out. Then reinstall the lower plug. Some electric motors have grease fittings installed and some have open lower holes without plugs.

Rotor-Tech, Inc.
 10613 Stebbins Circle
 Houston, TX 77043
 Phone: 713-984-8900
 Fax: 713-984-9425
 E-Mail: info@rotor-tech.com

Flow Rate
 US Gallons
 Pumped per minute
 (Theoretical*)

***Note:**
 Actual Flow Rate
 Depends on temperature,
 viscosity & pressure of
 fluid being pumped.

60HZ
 Recommended Minimum
 575 R.P.M. @ 20 Hz

50HZ
 Recommended Minimum
 480 R.P.M. @ 17 Hz

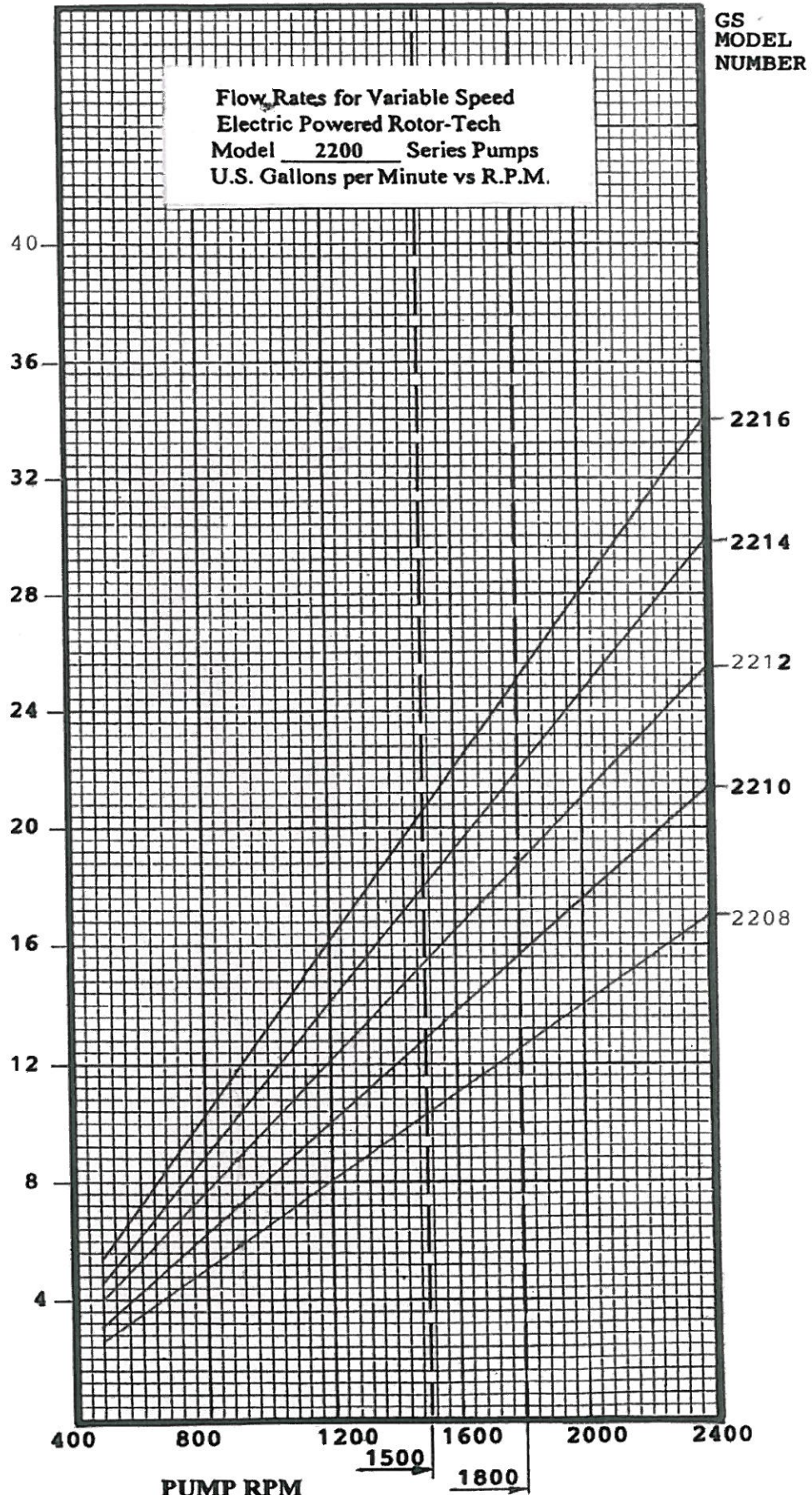

ROTOR-TECH, INC., SPECIALIZED GEAR PUMPS
ELECTRIC MOTOR DRIVE UNITS

EXAMPLE OF PIPING CONFIGURATION

This example shows piping of the ROTOR-TECH pump and Flo-Gage utilizing the Variable Speed Motor Drive method to accurately control flow rate.

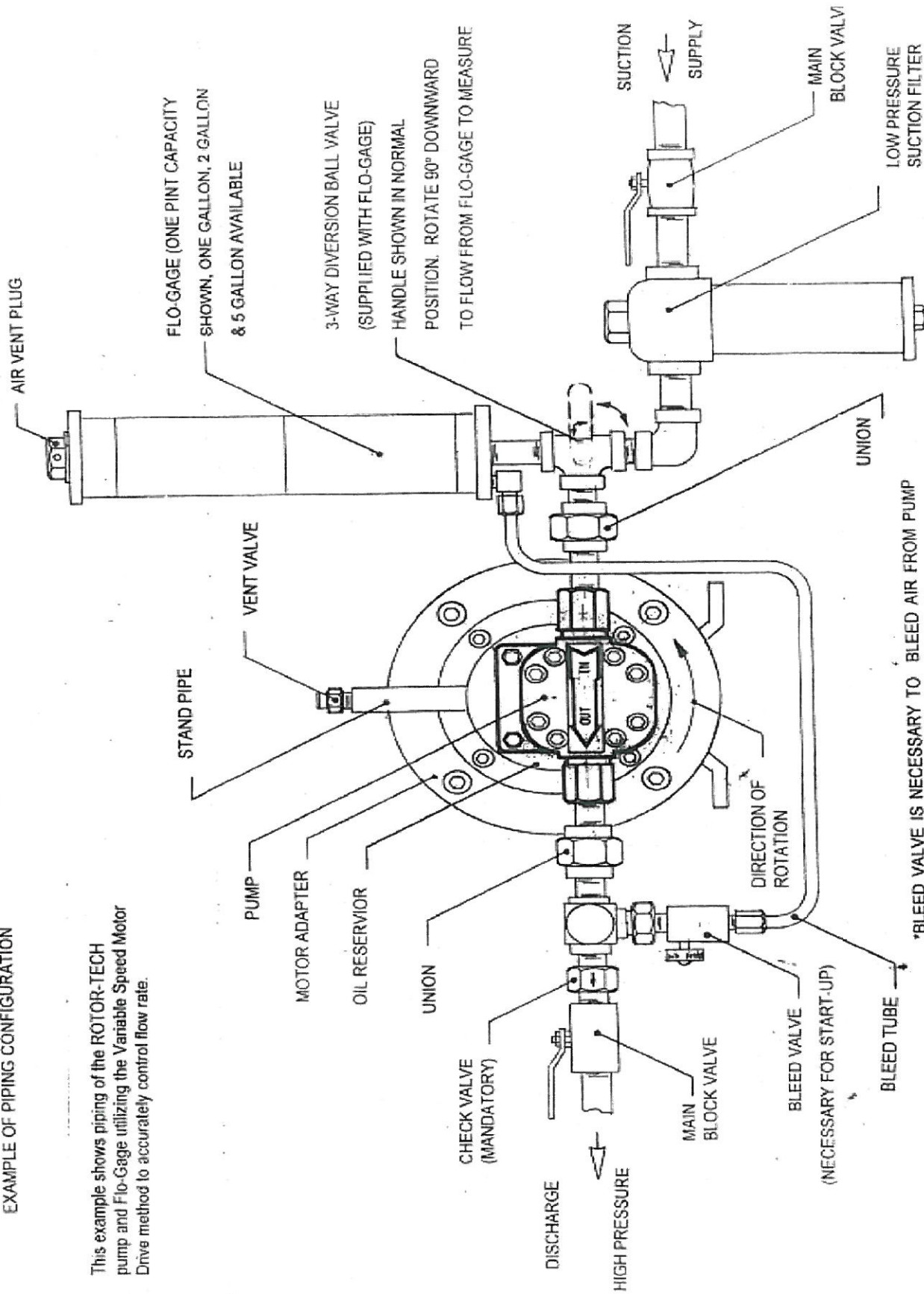

**ROTOR-TECH, INC.
SPECIALIZED ELECTRIC DRIVE GEAR PUMPS**

This example shows piping of the ROTOR-TECH pump and Flo-Gage utilizing the By-Pass method to accurately control flow rate. This arrangement is recommended when using a constant speed motor. Variable Speed motor drive units are also available from ROTOR-TECH, INC.

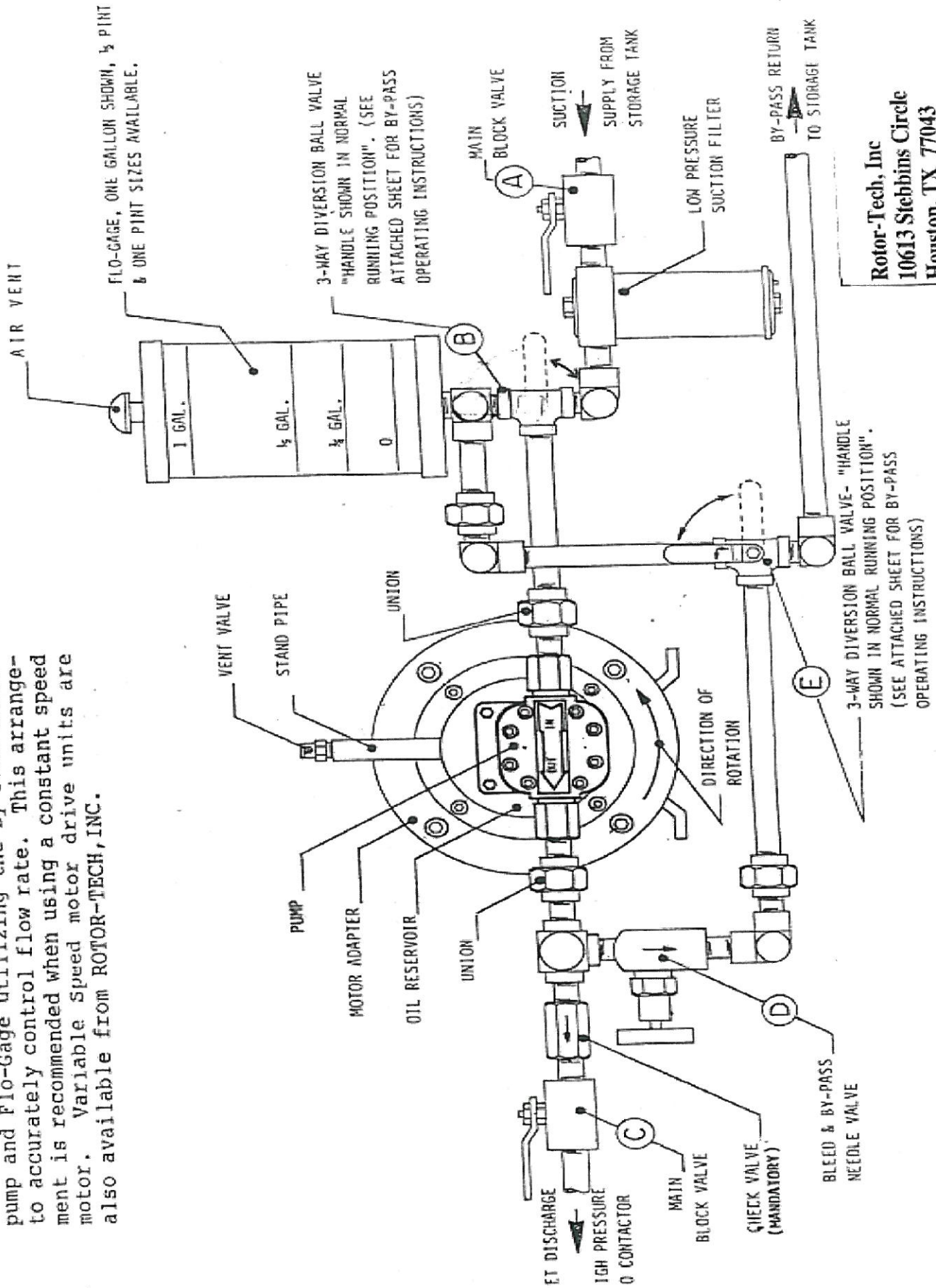

Rotor-Tech, Inc
10613 Stebbins Circle
Houston, TX 77043

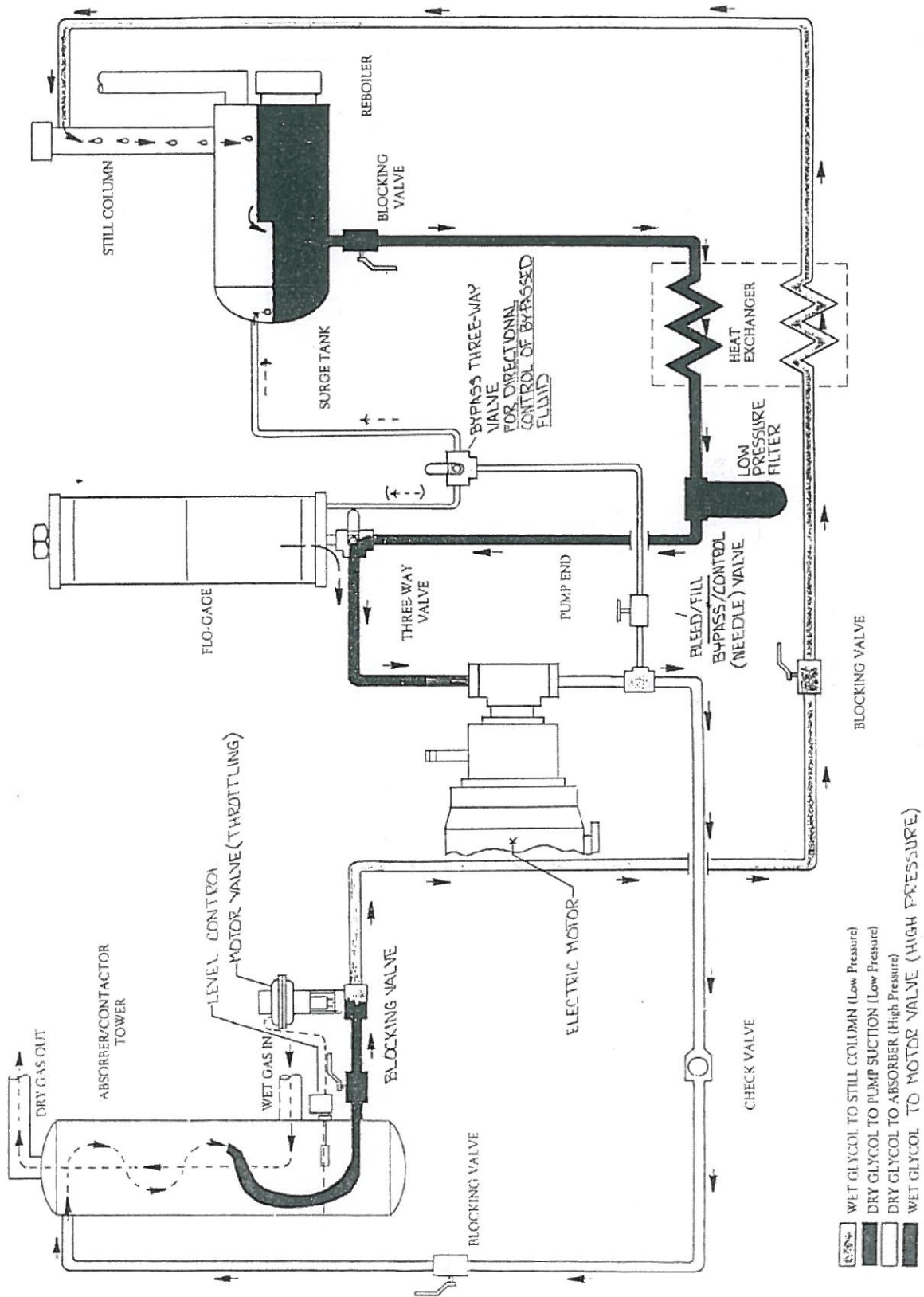

- WET GLYCOL TO STILL COLUMN (Low Pressure)
- - - DRY GLYCOL TO PUMP SUCTION (Low Pressure)
- · · DRY GLYCOL TO ABSORBER (High Pressure)
- ▬ WET GLYCOL TO MOTOR VALVE (HIGH PRESSURE)

WARNING

To: Any manufacturer or end user of Rotor-Tech Glycol Pumps.

DO NOT APPLY HIGH PRESSURE HYDROSTATIC TEST FLUID TO ANY ROTOR-TECH GEAR PUMPS OR MOTORS.

Rotor-Tech gear pumps and motors, as used on energy exchange glycol (TEG) pumps, or pumps that are driven electrically or pneumatically, are designed to operate at pressures to 2500 PSIG.

The shaft seal in the pump or motor is a special very high quality Teflon alloy lip seal. However, these seals should never be subjected to pressure exceeding 100 PSIG. They are intended only to separate glycol from lubricating oil in all Rotor-Tech pumps.

The construction of Rotor-Tech gear pumps and motors is such that a small pressure bleed-off hole is drilled from the low-pressure port (suction of a pump and discharge of a motor) to the seal face cavity. This is commonly called the "internal drain." It prevents build-up of pressure on the shaft seal.

If high pressure hydrostatic testing is done to Rotor-Tech pumps or motors, the shaft seal could fail allowing the test water to enter the oil reservoir. The water will displace all of the oil and will ruin the ball bearings and other pump or motor internals.

All Rotor-Tech gear pumps and motors are thoroughly run-in and hydro dynamically tested in TEG at high pressure before shipping.

When hydrostatically testing the dehydrator, close off all four blocking valves to the energy exchange pumps or the two blocking valves to the electric or pneumatic powered pumps. Be certain to drain off all water after testing. Do not allow water to enter a Rotor-Tech gear pump or motor. Water remaining in these components will corrode the close fitting gears and cause difficult starting and future problems. If water is allowed to freeze inside a pump or motor very serious damage will occur.

2014



Letter of Guarantee and Warranty

The products supplied under the above mentioned purchase order manufactured by Rotor-Tech, Inc. Houston, Texas are **guaranteed** to circulate triethylene glycol (TEG) in conventional gas dehydrator as well as certain other specified fluids in various types of applications when the units are properly installed, operated, maintained and cooled. The TEG or other specified fluid should be kept clean by proper filtration and not be allowed to become severely degraded. Fluid pH should also be maintained at adequate levels. Temperature of the fluid should be maintained below 200 ° F (93.3 C). **Note: The pump seals and internals are designed for TEG operating temperatures up to those stated above but it should be understood that temperatures should be maintained below this level for maximum pump efficiency and life.** Since there are extreme variations in field conditions, etc. and since Rotor-Tech has no control over the installation, use, care and maintenance of the Rotor-Tech product once it leaves our plant, there is **ABSOLUTELY NO GUARANTEE BY ROTOR-TECH, INC.** as to the operational life of the above listed products.

Rotor-Tech, Inc. **warrants** that should any pump or any part thereof prove to have been defective in material or workmanship at the time of shipment, such entire unit, or part, will be replaced FOB our factory without charge, for a period of 12 months after commissioning or 18 months after shipping providing permission is first obtained from our factory, and the unit or the parts are returned transportation charges prepaid. No allowances will be made for cost of labor, transportation, or other charges or costs involved in the replacement of parts, or an entire unit. Our warranty does not extend to any circumstantial or incidental damages (including loss of use or loss of profit) caused by failure of any glycol pump or accessories including, but not limited to, cost for removal and replacement inspection, cost of return or warehousing, cost of engineering, procurement and construction management services.

2014